

Tailift[®]

台勵福集團

機種齊全，因應市場需求
We Offer What You Need



高效率 旋臂鑽床

HIGH EFFICIENCY AND PRECISION

RADIAL DRILLS

www.tailiftgroup.com

手動夾緊 Manual Clamping

○ TPR-720A ○ TPR-820A ○ TPR-920A ○ TPR-1100

- 主軸正逆轉採用自製機械式切換開關，長期使用不易損壞。
- 旋臂採高級鑄體翻鑄而成，其滑軌更經嚴格熱處理及精密研磨。
- 二馬力標準馬達可提供重切削下多種不同速度的選擇。
- 主軸採用特殊彈簧平衡，此種平衡機構較傳統耐用。
- 內裝多項極限，超負荷保護裝置，可兼顧操作之安全性。
- 特製進刀深度輔助環，可隨時顯示主軸進刀深度達全程210mm。(適用於TPR-720A, TPR-820A, TPR-920A)
- In-built Mechanical switch for Forward/Reverse functions and longer service life with low maintenance.
- Arm Slider made upon high-class cast-iron and processed under severe Heat-Treatment and well Ground.
- 2HP motor can provide various speed selection under heavy-duty cutting.
- The main spindle is balanced by specially designed spring which is more durable than all other traditional balance mechanism.
- The over-load protective devices can secure the operator against injury.
- Extra auxiliary dial for spindle feed depth indication. With this indicator, we can review the momental feed depth of spindle 1 through 210mm at any moment. (for TPR-720A, TPR-820A, TPR-920A)



▲ TPR-720A



▲ TPR-920A



▶ TPR-820A



▶ TPR-1100

電鎖夾緊 Electric Clamping

○ TPR-1230

- 主軸正逆轉採用自製機械式切換開關，長期使用不易損壞。
- 旋臂採高級鑄體翻鑄而成，其滑軌更經嚴格熱處理及精密研磨。
- 三馬力變極馬達可提供重切削下多種不同速度的選擇。
- 內裝多項極限，超負荷保護裝置，可兼顧操作之安全性。
- In-built Mechanical switch for Forward/Reverse functions and longer service life with low maintenance.
- Arm Slider made upon high-class cast-iron and processed under severe Heat-Treatment and well Ground.
- 3HP two speeds motor can provide various speed selection under heavy-duty cutting.
- The over-load protective devices can secure the operator against injury.



◀ TPR-1230



電動夾緊型(TPR-1230)
Electric clamping (TPR-1230)

油壓夾緊 Hydraulic Clamping

○ TPR-1230H ○ TC-1250H ○ TC-1600H ○ TPR-1600H ○ TPR-2000H ○ TPR-C2500

- 旋臂升降係採用電子計時器控制，啟動按鈕即可完成旋臂自動放鬆並垂直升降，或升降停止並自動夾緊作業，易於操作，並在換刀後仍可保持原刀具中心位置。
- 旋臂升降機構附有安全裝置，以防止多年以後，因升降銅螺母過度磨損而旋臂突然掉落。
- 內裝齒輪專用型機油循環泵浦，以冷卻齒輪箱內精密齒輪，可降低齒輪過度磨損。
(適用於 TPR-1600H, TPR-2000H, TPR-C2500)
- 摩擦型離合器可吸收主軸所產生縱向衝擊力，故能有效地保護齒輪箱內所有傳動元件，並具有主軸快速回位功能，可加快攻牙作業速度。
(適用於 TPR-1600H, TPR-2000H, TPR-C2500)
- 機柱、旋臂、齒輪箱可同時夾緊，設有按鈕開關可使用。除 TPR-1600H 及 TPR-2000H 採用十字開關，其餘機種採用按鈕開關控制。
- 備有特殊設計自動退刀裝置，可大大增進退刀效率。
(適用於 TPR-1600H, TPR-2000H)
- 機柱、旋臂、齒輪箱可個別夾緊或同時夾緊，設有選擇開關可使用。
(適用於 TPR-C2500)
- 速度轉換採油壓傳動設計，且裝有速度預先調整裝置，快速且易於操作。
(適用於 TPR-C2500)
- The Radial Drill Arm adopts IC Timer with advantage of one bottom press, it can automatically release up/down movement, stop, and automatically clamping easy to operate. The spindle can still maintain in original set after the tools change.
- Special arm elevating safety device is provided to prevent arm from falling down abruptly after year of usage. It will keep us from injurious dropping whenever the copper nut is excessively worn.
- Exclusively for gears type cycling oil pump is furnished to cool off precise gears inside gear box, and minimize excessive wear on gears to lowest extent. (for TPR-1600H, TPR-2000H, TPR-C2500)
- Friction type disc clutch is adopted to absorb impact force caused by vertical movement of spindle, and effectively protect all transmission unit inside gear box. With the function of quick spindle return, this clutch will also help us to speed up our tapping operation. (for TPR-1600H, TPR-2000H, TPR-C2500)
- Column, Arm, Gear box can clamp at same time by a push button for all model machines except TPR-1600H and TPR-2000H which use cross switch.
- Automatic tool releasing device effectively increases tool changing. (for TPR-1600H, TPR-2000H)
- Equipped with hydraulic clamping system, with proper selection on change switch, column, arm, gear box can be clamped/released independently. (for TPR-C2500)
- Speed Changing function is driven by hydraulic power and equipped with quick preset device for TPR-C2500.

標準附件

- 調節用工具 (含工具箱) ... 1套
- 冷卻裝置 (含泵浦) ... 1套
- 照明裝置 (含日光燈) ... 1套
- 箱型工作檯 ... 1套

Standard Accessory:

- Adjustment tools (box included) 1 set
- Cooling device (pump included) 1 set
- Lighting device (fluorescent lamp included) 1 set
- Box-type work table 1 set

特殊附件

- 可傾斜工作檯 1套
- 單式傾斜工作檯，可傾斜到90度，有刻度指示針可告知傾斜度。
- 可傾斜工作檯亦可用於其他加工工作母機上面。

- 攻牙器-DT33-MT#4..... 1套
- 攻牙器-DT33-MT#5..... 1套
- 萬能夾具-5/8"..... 1套
- 萬能夾具-3/4"..... 1套
- 萬能夾具-18mm..... 1套

Special Optionals/Tilt Tables

Uni-tilt table tilts full 90 degrees. Calibrated indicator shows degree of tilt has accurately planed top.

- DT33-MT#4 Drill Tapping Set 1 set
- DT33-MT#5 Drill Tapping Set 1 set
- 5/8" Clamping Kits 1 set
- 3/4" Clamping Kits 1 set
- M18 Clamping Kits 1 set

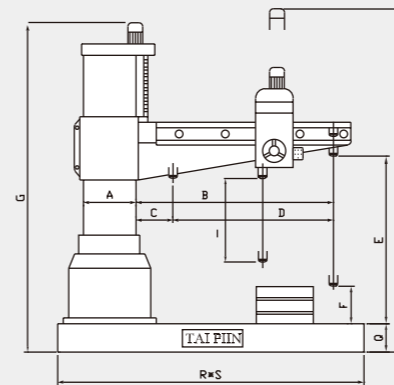

尺寸規格 (長×寬×高)

1. 810×710×610m/m (大)
2. 520×510×570m/m (小)

Dimensions (L x W x H)

1. 810x710x610m/m (Large size)
Application: TC-1250H/TC-1600H/TPR-1600H
TPR-2000H/TPR-C2500
2. 520x510x570m/m (Small size)
Application: TPR-720A-1600H



▲ TPR-1230H



▲ TC-1250H



▲ TC-1600H



▲ TPR-1600H

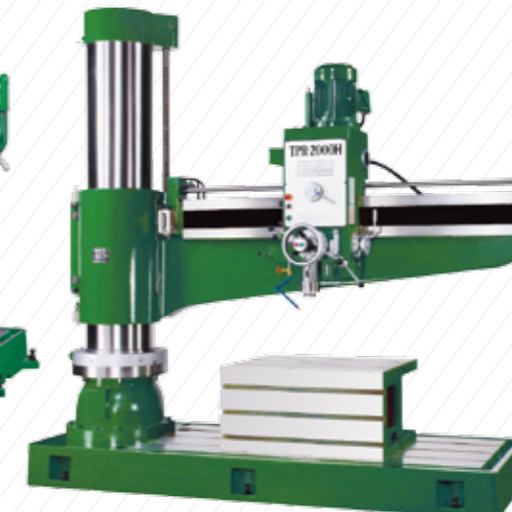

▲ TPR-2000H



▲ TPR-C2500



油壓夾緊型(TC-1250H, TC-1600H)
Hydraulic clamping (TC-1250H, TC-1600H)

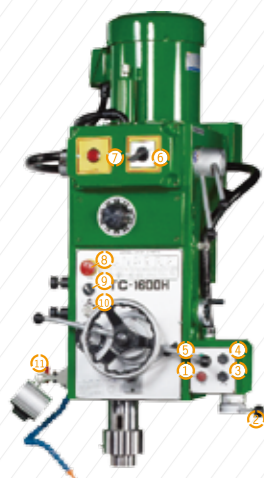

- ① 鎖緊開關
P/B switch for clamping
- ② 主軸正反轉開關
Lever for spindle forward/reverse turn
- ③ 臂手下降開關
P/B switch for arm down
- ④ 臂手上升開關
P/B switch for arm uplift
- ⑤ 放鬆開關
P/B switch for release
- ⑥ 變極開關
Pole change switch
- ⑦ 電流指示燈
Power indicator
- ⑧ 緊急開關
Emergency stop switch
- ⑨ 切削液切換開關
Coolant water switch
- ⑩ 進給電源指示燈
Feed indicator
- ⑪ 切削液調整開關
Coolant water adjust switch

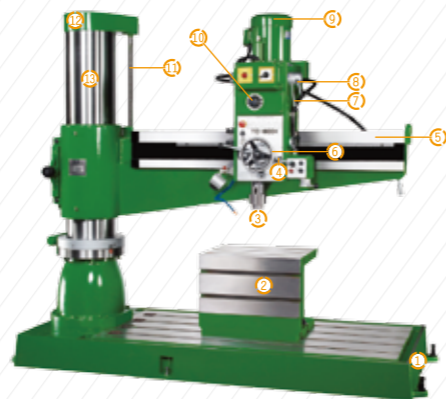

- ① 底座
Base
- ② 箱型工作檯
Box-type work table
- ③ 主軸
Spindle
- ④ 進刀撥桿
Feed lever
- ⑤ 臂手
Arm
- ⑥ 手輪
Handwheel
- ⑦ 三段變速桿
Three step speed change lever
- ⑧ 二段變速桿
Two step speed change lever
- ⑨ 主軸馬達
Main motor
- ⑩ 進給速率切換開關
Feed rate change switch
- ⑪ 傳動導螺桿
Lead screw
- ⑫ 帽蓋
Top cover
- ⑬ 大柱
Column



- ① ② 進刀速率選擇
Structure of feed lever
- ③ 退刀控制桿
Ejecting lever
- ④ 離合器控制桿
Hom
- ⑤ 十字開關
Cross switch
- ⑥ 進刀手動/自動控制桿
Swing lever
- ⑦ 變速桿
Change lever
- ⑧ 高/低速；正/逆轉選擇桿
H.L change lever
- ⑨ 微調進刀手輪
Limit hand wheel
- ⑩ 油鏡
Machine oil indicator
- ⑪ 夾緊鈕
Red, clamp button
- ⑫ 放鬆鈕
Green, release button

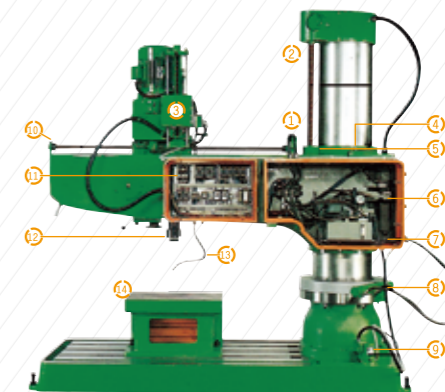

- ① 控制齒箱鎖緊放鬆之油
Oil cylinder base for fasten & loosen gear box
- ② 導螺桿
Leading screw
- ③ 主軸重力平衡裝置
Spindling weight counter balance unit
- ④ 上極限開關
Limit switch, upper
- ⑤ 旋臂升/降安全裝置
Special arm raising safety device
- ⑥ 油壓控制鈕
Hydraulic control unit
- ⑦ 下極限開關
Limit switch, lower
- ⑧ 油壓缸
Hydraulic cylinder
- ⑨ 冷卻泵浦
Coolant pump
- ⑩ 齒箱鎖緊放鬆導桿
Leader for fasten & loosen gear box
- ⑪ 電氣控制箱
Electric control unit
- ⑫ 主軸/排齒管組
Spindle and quill
- ⑬ 冷卻噴嘴
Coolant nozzle
- ⑭ 箱型工作檯
Plain box table

Unit/mm

型號 / MODEL		TPR-720A	TPR-820A	TPR-920A	TPR-1100	TPR-1230	
大柱直徑	Dai.of column	210		260	300	A	
主軸中心至機柱表面距離-最大	Distance from column surface to spindle center, Max	750	850	950	1120	1230	D+C
主軸中心至機柱表面距離-最小	Distance from column surface to spindle center, Min	225	230	210	270	330	C
主軸頭部在旋臂上水平移動行程	Travel of spindle head	540	640	755	850	880	D
主軸末端至底座加工距離-最大	Distance from base surface to spindle end, Max	1050	1210	1225	1280	1360	E
主軸末端至底座加工距離-最小	Distance from base surface to spindle end, Min	260	375	385	480	467	F
旋臂在機柱上垂直升降行程	Elevating height of Arm	580	625	625	560	620	E-F-I
箱型工作檯尺寸有效工作範圍	Effective area of box table	600x445x380		635x520x415	635x520x415	LxKxH	
底座尺寸(長x寬x厚)	Dimension of base	1250x640x160	1250x640x160	1260x640x160	1720x715x185	1720x715x185	RxSxQ
主軸孔模式推拔番號	Taper hole spindle	MT#4		MT#4	MT#4		
主軸垂直行程	Stroke of spindle	210		240	270	I	
主軸轉速 (空載轉速/分鐘x段數)	R.P.M of spindle (rpm x steps)	50HZ	73~1247x6		37~1253x12		
		60HZ	88~1500x6		44~1500x12		
主軸進刀速(mm/轉x段數)	Feed of spindle (rev.x steps)	0.05, 0.09, 0.15x3		0.05, 0.09, 0.15x3	0.05, 0.09, 0.15x3		
主軸驅動馬達馬力數	Main motor (HP)	2HP		3(two speed motor)	3(two speed motor)		
旋臂升降馬達馬力數	Elevating motor (HP)	1HP		1HP	1HP		
機柱•旋臂•夾緊裝置馬力數	Clamping motor(HP)				1HP		
冷卻泵浦馬達馬力數	Coolant equipment (HP)	1/8HP		1/8HP	1/8HP		
齒輪箱頂端至地面距離-最大	Machine height from floor (Max.)	2160	2320	2340	2570	2670	M
機柱帽蓋頂端馬達至地面高度	Base + column height	1820	2010	2020	1990	2070	G
單機淨重(約)	Net weight (approx)kgs	1175	1200	1280	1800	2100	
裝箱後毛重(約)	Shipping weight (approx)kgs	1320	1350	1400	1950	2300	
裝箱尺寸(長x寬x高)	Shipping dimensions (LxWxH)	1630x810x2160	1680x810x2210	1800x810x2210	1880x860x2210	2030x990x2240	
工作 能力 Capacity	鑽孔 Drilling	中碳鋼 Steel	32Φ		42Φ	42Φ	
		鑄鐵 Cast iron	50Φ		55Φ	55Φ	
	攻牙 Tapping	中碳鋼 Steel	25Φ		25Φ	25Φ	
		鑄鐵 Cast iron	32Φ		38Φ	38Φ	

* 上述列示規格公差介於 +/-5mm

* 以上參數僅供參考，如有變更恕不另行通知。

* Above listed specifications are within +/-5mm tolerances.

* Above specifications for reference only, modifications are not subject to notice in advance.

Unit/mm

型號 / MODEL		TPR-1230H	TC-1250H	TC-1600H	TPR-1600H	TPR-2000H	TPR-C2500	
大柱直徑	Dai.of column	300	300	320	432	432	550	A
主軸中心至機柱表面距離-最大	Distance from column surface to spindle center, Max	1230	1275	1650	1550	2060	2500	D+C
主軸中心至機柱表面距離-最小	Distance from column surface to spindle center, Min	330	305	330	440	440	500	C
主軸頭部在旋臂上水平移動行程	Travel of spindle head	880	970	1320	1110	1620	2000	D
主軸末端至底座加工距離-最大	Distance from base surface to spindle end, Max	1360	1330	1405	1640	1950	2000	E
主軸末端至底座加工距離-最小	Distance from base surface to spindle end, Min	467	438	465	380	395	550	F
旋臂在機柱上垂直升降行程	Elevating height of Arm	620	625	670	875	1185	1000	E-F-I
箱型工作檯尺寸有效工作範圍	Effective area of box table	635x520x415	635x520x420	630x500x500	700x500x400	1000x800x500	1000x800x560	LxKxH
底座尺寸(長x寬x厚)	Dimension of base	1720x715x185	1830x785x185	2550x970x200	2470x1030x200	2920x1120x260	3520x1400x320	RxSxQ
主軸孔模式推拔番號	Taper hole spindle	MT#4	MT#5		MT#5		MT#6	
主軸垂直行程	Stroke of spindle	270	270		370		450	I
主軸轉速 (空載轉速/分鐘x段數)	R.P.M of spindle (rpm x steps)	50HZ	37~1253x12	44~1206x12	29~1575x12	16~1250x16		
		60HZ	44~1500x12	56~1450x12	35~1890x12	16~1250x16		
主軸進刀速(mm/轉x段數)	Feed of spindle (rev.x steps)	0.05, 0.09, 0.15x3	0.06, 0.10, 0.20x3	0.07-0.96x6	0.04-3.20x16			
主軸驅動馬達馬力數	Main motor (HP)	3(two speed motor)	5(two speed motor)	7-1/2HP	10HP			
旋臂升降馬達馬力數	Elevating motor (HP)	1HP	1HP	2HP	2HP	3HP	5HP	
油壓泵浦馬達馬力數	Hydraulic clamping motor(HP)	1HP	1HP	1HP	1HP		1HP	
冷卻泵浦馬達馬力數	Coolant equipment (HP)	1/8HP	1/8HP	1/8HP	1/8HP		1/4HP	
齒輪箱頂端至地面距離-最大	Machine height from floor (Max.)	2670	2795	2790	3130	3520	3990	M
機柱帽蓋頂端馬達至地面高度	Base + column height	2070	2070	2190	2660	3050	3850	G
單機淨重(約)	Net weight (approx)kgs	2100	2300	3300	4250	5600	11000	
裝箱後毛重(約)	Shipping weight (approx)kgs	2300	2500	3650	4700	6100	12500	
裝箱尺寸(長x寬x高)	Shipping dimensions (LxWxH)	2030x990x2240	2220x1000x2240	2700x1130x2430	2820x1450x2930	3200x1450x3300	4160x1880x3850	
工作 能力 Capacity	鑽孔 Drilling	中碳鋼 Steel	42Φ	50Φ	65Φ	80Φ		
		鑄鐵 Cast iron	55Φ	60Φ	70Φ	100Φ		
	攻牙 Tapping	中碳鋼 Steel	25Φ	40Φ	50Φ	65Φ		
		鑄鐵 Cast iron	38Φ	50Φ	60Φ	75Φ		

* 上述列示規格公差介於 +/-5mm

* 以上參數僅供參考，如有變更恕不另行通知。

* Above listed specifications are within +/-5mm tolerances.

* Above specifications for reference only, modifications are not subject to notice in advance.

Vertrauen Sie auf über 70 Jahre Erfahrung!

Die Firma HESSE+CO wurde 1947 als Hersteller von Blechbearbeitungsmaschinen gegründet. Seit 1980 sind wir auf den Handel mit neuen sowie gebrauchten Blechbearbeitungs- und Werkzeugmaschinen spezialisiert. Wir haben ständig etwa 300 Maschinen in unserer 2.000 m² großen Ausstellungshalle, die nur 20 Minuten vom internationalen Flughafen Wien entfernt ist.

Trust in more than 70 years of experience!

HESSE+CO was established in 1947 as a manufacturer of sheet metal working machines. Since 1980 we are specialized in dealing with new and second hand sheet metal processing machines and machine tools. We always have approximately 300 machines available in our 2.000 m² showroom, which is located only 20 minutes from the Vienna International Airport, waiting for your inspection.

www.hesse-maschinen.com

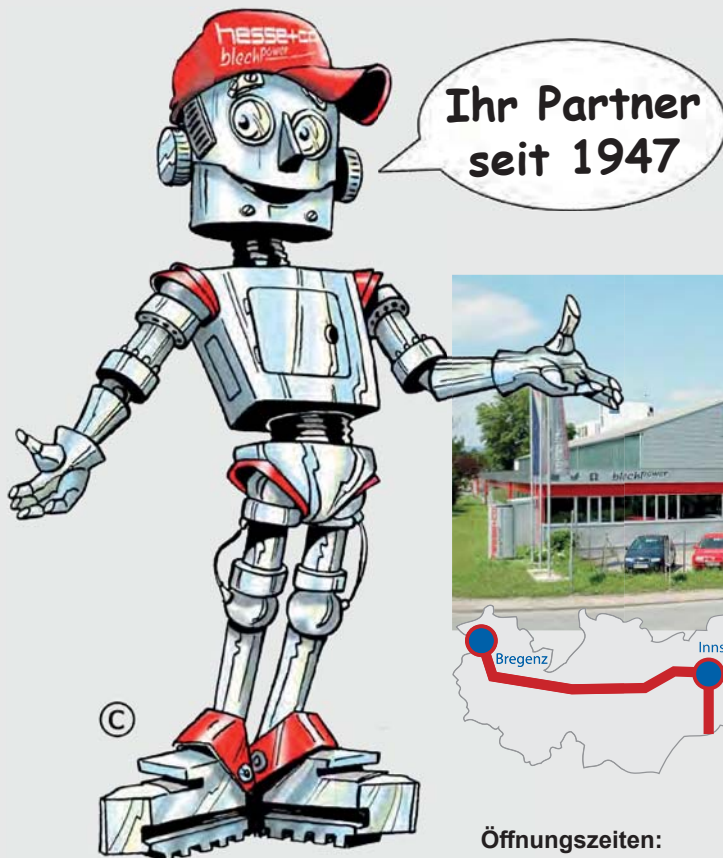

Öffnungszeiten:

Mo - Do 8:00 - 16:30 Uhr
Fr 8:00 - 14:30 Uhr

HESSE+CO Maschinenfabrik GmbH
Industriezentrum NÖ-Süd
Straße 4 - Objekt 8
A-2351 Wiener Neudorf
AUSTRIA

hesse **hesse+co**
blechpower
maschinen und werkzeuge

Technische Änderungen, Irrtum und Druckfehler vorbehalten.
Gültig bis auf Widerruf.

Tel.: +43/2236/638 70-0
Fax: +43/2236/636 62
office@hesse-maschinen.com
www.hesse-maschinen.com
www.blechpower.com